

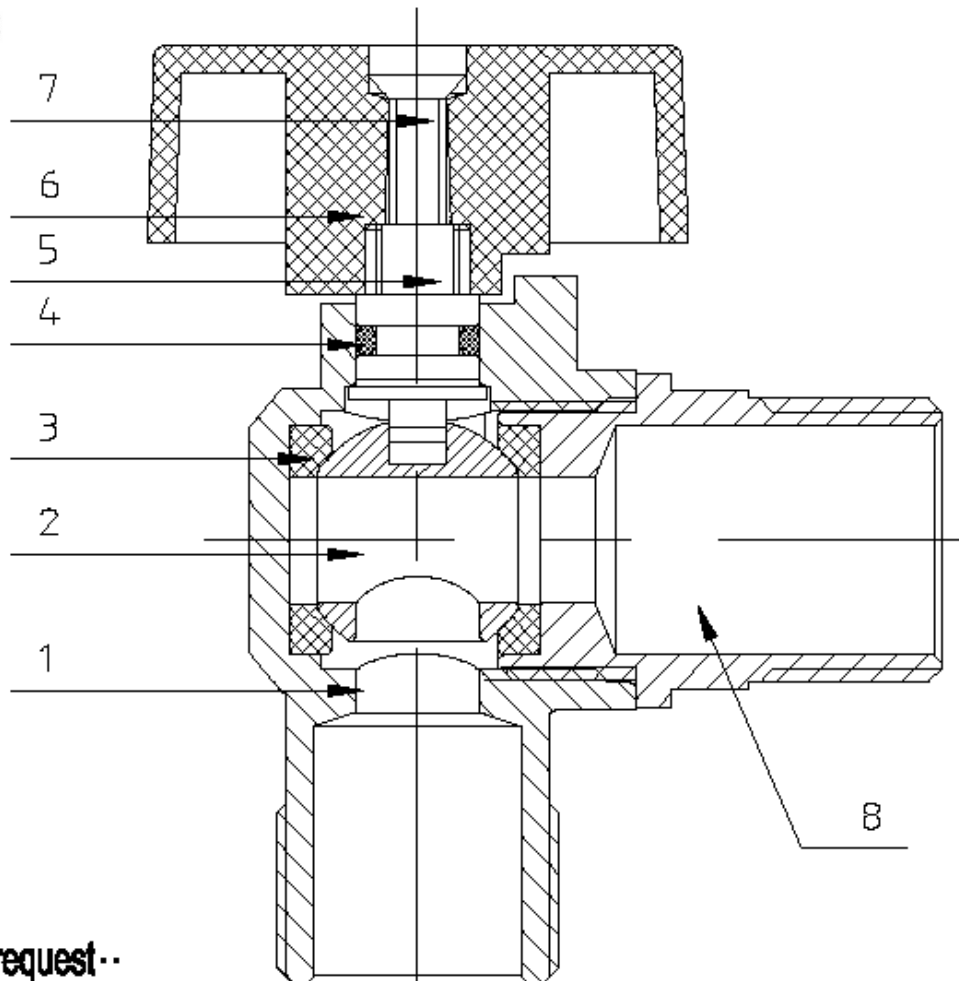

CHRYSSAFIDIS

ΓΩΝΙΑΚΟΙ ΣΦΑΙΡΙΚΟΙ ΚΡΟΥΝΟΙ



technique request..

- 1 ,all the seal component should be smear oil .
- 2 ,turn the stem,it should be freely and smooth , correct angle .
- 3 ,test under pressure 0.8MPa keep 6 seconds, guarantee without any leakage for 8 hours .
4. the normal work pressour<1.6MPa, normal temperature <120,

8	cap	1	HPb59-1	255684		plated nickel
7	M4 bolt	1	Fe	252131		总长18mm有效螺纹16mm
6	handle	1	ABS	355211		chrome plated
5	stem	1	HPb59-1	255641		brass
4	O-ring	1	NBR	300379		φ9x1.6 70°
3	seat	2	PTEF	355191		φ16.5xφ9.2x3
2	ball	1	HPb59-1	255750		plated chrome
1	body	1	HPb59-1	155453		plated nickel
No.	description	quantity	material	code	weight	remark

1/2" x 1/2" / 1/2" x 3/4" ANGLE VALVE

KF-J001