

FIG NO: TH: 620118
SW: 620128

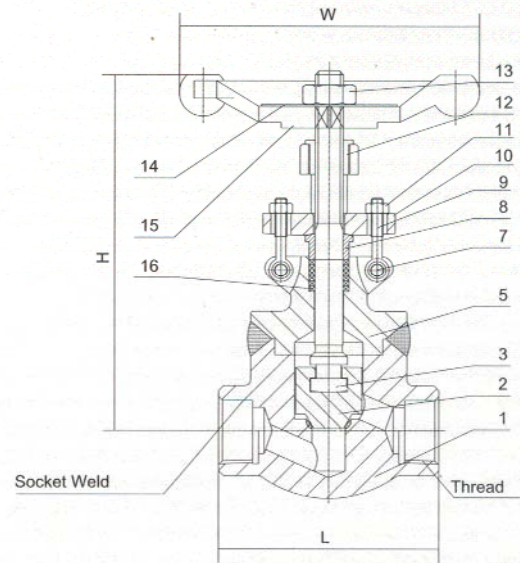

FIG NO: TH: 620218
SW: 620228

Standard Material Specifications

NO.	Part Name	CS To ASTM	AS To ASTM	SS To ASTM	
		Type A105	Type LF2	Type F304(L)	Type F316(L)
1	Body	A105	A182 LF2	A182 F304(L)	A182 F316(L)
2	Disc	A276 420	A276 304	A276 304(L)	A276 316(L)
3	Stem	A182 F6	A182 F304	A182 F304(L)	A182 F316(L)
4	Gasket	Corrugated SS+graphite		SS+PTFE	
5	Bonnet	A105	A276 304	A276 304(L)	A276 316(L)
6	Bonnet Bolt	A193 B7	A193 B16	A193 B8	A193 B8M
7	Pin	A276 420		A276 F304	
8	Gland	A276 410		A182 F304(L)	A182 F316(L)
9	Gland Eyebolt	A193 B7	A193 B16	A193 B8	A193 B8M
10	Gland Flange	A216 WCB		A351 CF8	
11	Gland Nut	A194 2H	A194 4	A194 8	A194 8M
12	Yoke Nut	A276 410			
13	H.W.Lock Nut	A194 2H	A194 4	A194 8	A194 8M
14	Nameplate	SS			
15	Handwheel	A197			
16	Stem Packing	Flexible Graphite		PTFE	
Suitable Medium		W.O.G.etc	W.O.G.etc	HNO ₃ ,CH ₃ OOH etc	
Suitable Temperature		-29°C~425°C	-29°C~550°C	-29°C~180°C	

Note:Other materials are available upon request.
CS=Carbon Steel;AS=Alloy Steel;SS=Stainless Steel;

Dimensions(mm) and Weights(Kg)

NPS	Conv.	3/8"	1/2"	3/4"	1"	1 1/4"	1 1/2"	2"	
	Full		3/8"	1/2"	3/4"	1"	1 1/4"	1 1/2"	2"
L		79	79	92	111	120	152	172	200
H(OPEN)		166	166	171	207	240	258	330	355
W		100	100	100	125	160	160	180	200
Weights	Bolted	1.9	1.9	2.1	3.5	6.0	7.5	11.4	14.6
	Welded	1.7	1.7	1.9	3.3	5.2	6.8	10.6	13.8

**DESIGN AND MANUFACTURE:**

API 602, API 606, BS 5352, BS 6364, AND ASME B 16.34

TEST PRESSURE TO:

API 598 AND MARKING IS PER MSS SP-25

SOCKET WELD ENDS TO:

ASME B 16.11

SCREWED ENDS (NPT) TO:

ANSI/ASME B 1.20.1

**CONSTRUCTION IS AS FOLLOWS:**

- * FULL PORT OR CONVENTIONAL PORT
- * OUTSIDE SCREW AND YOKE (OS&Y)
- * TWO PIECE SELF ALIGNING PACKING GLAND
- * INTEGRAL BACKSEAT
- * BOLTED BONNET WITH SPIRAL-WOUND GASKET, THREADED AND -
- SEAL WELDED BONNET OR THREADED AND PRESSURE SEAL BONNET

ABOUT FORGED STEEL VALVES

Fluval valves are available in three bonnet designs. The first design is the Bolted Bonnet, with male-female joint, spiral wound gasket, made in F304L/graphite. Ring joint gasket are also available on request. The second design is the welded bonnet, with a threaded and seal welded joint. On request a full penetration strength welded joint is available. The third design is the pressure seal bonnet, with a threaded and pressure seal bonnet joint.